

REAL-TIME AND CONTINUOUS OUTPUT POWER MONITORING OF PHOTOVOLTAIC (PV) SYSTEMS

SYAFARUDDIN*, NELLA CHINTIA MENDENG, PILIPUS MASTER
AND ZAENAB MUSLIMIN

Department of Electrical Engineering
Universitas Hasanuddin

Tamalanrea-Makassar 90245, Indonesia

*Corresponding author: syafaruddin@unhas.ac.id

Received December 2013; accepted February 2014

ABSTRACT. *The output characteristics of photovoltaic systems are non-linear to the environmental factors and unique to different types of solar cells technology. For this reason, it is very interesting to see how it varies through the output power visualization in real-time. The real-time output with continuous measurement is possible due to the rapid development of sensors and electronic devices. The fundamental design of real-time measurement system is based on the utilization of Hall Effect of ACS712 current and voltage sensors. The output parameters of these two sensors are processed in microcontroller ATmega8535 in order to obtain output power in real-time and continuously visualized in liquid crystal display (LCD) or in computer monitor. The performance of microcontroller ATmega8535 and sensors circuits are regulated using C++ combined with Visual Basic 6.0 language programming for display interface and database systems. Several testing have been demonstrated to show the quality performance of our proposed design system.*

Keywords: Real-time, Monitoring system, Output power, Microcontroller circuit, PV systems

1. Introduction. Real-time and continuous monitoring of output power of photovoltaic system is very important in practice. It is helpful in gaining insights to the dynamic behavior and interactions that are not often readily apparent from reading theory. In addition, it may overcome the field testing which is costly and time consuming for investigating the dynamics characteristics of photovoltaic (PV) system [1,2]. In associated with the PV system behavior, the output power characteristic for the commercial available Silicon solar cell is very different and it cannot be generalized for various technologies of solar cell [3]. The conventional crystalline Silicon solar cells have performance degradation in heat, reverse in cold. This kind of characteristic is improved in thin-film Silicon solar cell technology and significantly enhanced by well performance in heat and dim lights. The effect of reducing output power due to the increase in operation temperature is not found any more in advanced thin film nanocrystalline hybrid cells and the heterojunction cells based on Copper Indium Diselenide (CIS) and Cadmium Telluride (CdTe) as well as in Copper-Indium-Gallium-Diselenide (CIGS) based new thin film solar cells technology [4].

According to variability of output power due to environmental factors and different responses in different solar cell technologies, it is very interesting to visualize how the output power of photovoltaic system installation is continuously changed in real-time measurement [5]. Visualization is defined in this respect as the graph or certain number appears on screen that represents the output power of photovoltaic system from time to time operation. This kind of visualization is very attractive to be seen as a part of photovoltaic system campaign in the PV location [6]. For instance, if the real-time output monitoring system is available for PV system installation facility, the output profile can

be interactively shown and displayed in big LCD screen, even the location of PV system might not be seen physically. People can observe the output of the system from time to time which compares to the physical weather condition either sunny bright or partially cloudy. Of course, fluctuation output is always figured out on the screen that makes one of the interesting points of photovoltaic system installation [7].

Real-time modeling has been an important technique to view the output behavior of photovoltaic systems. An iterative method for the time-varying parameters was proposed to model a plant of PV array of 30 kW in China [8]. Another approach of modeling is to consider outdoor operating condition measurement to predict the output power of PV system on certain location standard which testing conditions cannot be achieved [9]. However, this method may suffer from low accuracy due to the environmental factor between PV sites which is totally different and the type of PV module technology which is very sensitive to the irradiance and ambient temperature. Model of real-time prediction of output power and energy for grid connected photovoltaic system in Macau is proposed based on certain ratio between the predicted powers and the predicted irradiance level [10]. However, this method is important to be investigated further for the reason that the ratio may guarantee works in other PV site locations.

The utilization of microcontroller for real-time output monitoring of photovoltaic system has gained much research attention in the last decade. It is due to the compact design, easy implementation, low cost material and high performance control. For instance, for real-time output processing, photovoltaic system is embedded with TMS320F2812 32-bit microcontroller [11]. Similar to our research, [11] also processed data from Hall sensor measurement and both software and hardware have been properly tested. In other research, the development of an FPGA-based system for real-time simulation of photovoltaic modules is proposed to enhance the rapid system prototyping capability, to enable the reduction of the power converter size and cost due to the high clock speed feature of the FPGA-based control unit [12]. In addition, modular strategy for isolated photovoltaic system with microcontroller may improve the accuracy maximum power point tracking algorithm [13]. For similar research consideration in order to design low cost and high efficiency of maximum power point tracking control, microcontroller PIC 16F876 and AVR ATmega16 types are utilized [14,15]. All research results show that the use of microcontroller may improve overall control performance in terms of speed and accuracy and be very powerful for data communication and database information systems.

The outline of the paper is presented as follows. It begins with the fundamental design of real-time and continuous measurement of photovoltaic system based on two sensors utilization; i.e., Hall effect of ACS712 current sensor and voltage sensor, microcontroller ATmega8535 circuit processor and LCD display. It follows the explanation of C++ programming language utilization combined with Visual basic 6.0 programming language for interface and database systems. Finally, the experiment on PV module system is performed using developed real-time monitoring output power PV system.

2. Fundamental Design of Proposed Real-Time Monitoring System. The schematic diagram of our proposed design for real-time visualization of output power of photovoltaic systems is shown in Figure 1. The main components are the current sensor of ACS712 circuit and voltage sensor as voltage divider circuit. The analog signal produced by these two sensors is then converted to digital signal using microcontroller ATmega8535 through port A.0 (output of voltage sensor) and port A.1 (output of current sensor). The digital signal is processed in microcontroller circuit to produce the real-time and continuous output power monitoring that can be displayed in liquid crystal display and/or computer monitor. Therefore, the sensor circuits, microcontroller circuit and other supported components are explained as follows.

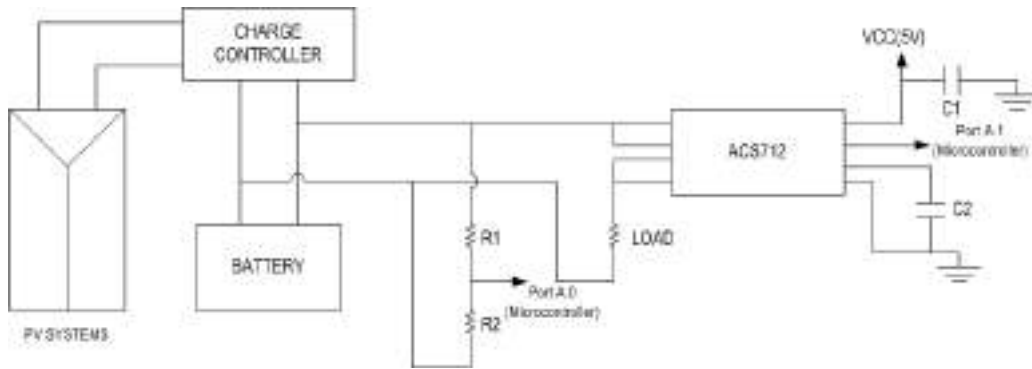

FIGURE 1. The schematic diagram of real-time output power visualization of PV systems

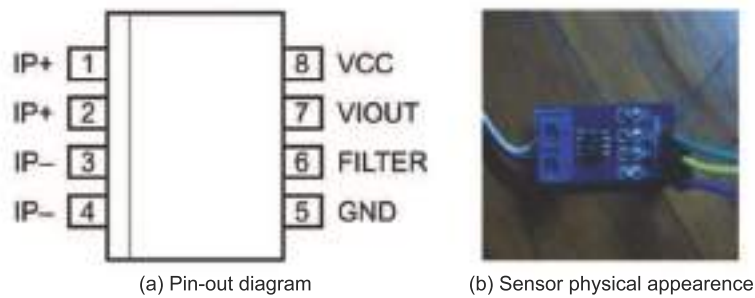

FIGURE 2. Current sensor circuit of ACS712

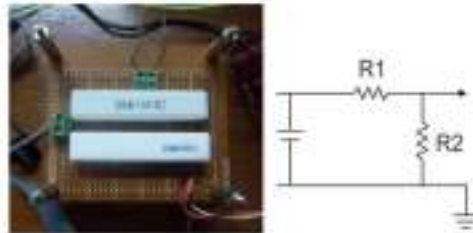

FIGURE 3. Voltage sensor circuit

2.1. Current sensor circuit of ACS712. The type of current sensor of ACS712 with current rating of 0-5 A is utilized in this research. The pin-out diagram of ACS712 current sensor can be seen in Figure 2. The sensor is supported by Hall Effect technology to replace the necessity of the shunt resistor and current transformer for the conventional current measurement technique that makes a compact small size. The flow of electric current creates magnetic field induction to the dynamic offset cancellation part of ACS712. The signal produced in this part is then amplified and filtered before reaching the output ports of 6 and 7.

2.2. Voltage sensor circuit. Voltage sensor is a well-known sensor to determine the network voltage instantaneously. In this research, the voltage sensor is the voltage divider that consists of high value resistance, i.e., R1: 445 Ω and R2: 85 Ω . With this approach, the output voltage from photovoltaic system is converted to about 5 V following the input voltage requirement of microcontroller. The physical appearance and voltage sensor circuit is shown in Figure 3.

2.3. Microcontroller ATmega8535 circuit. The type of microcontroller used in this research is ATmega8535 as one of the Atmel product based on the AVR technology. The

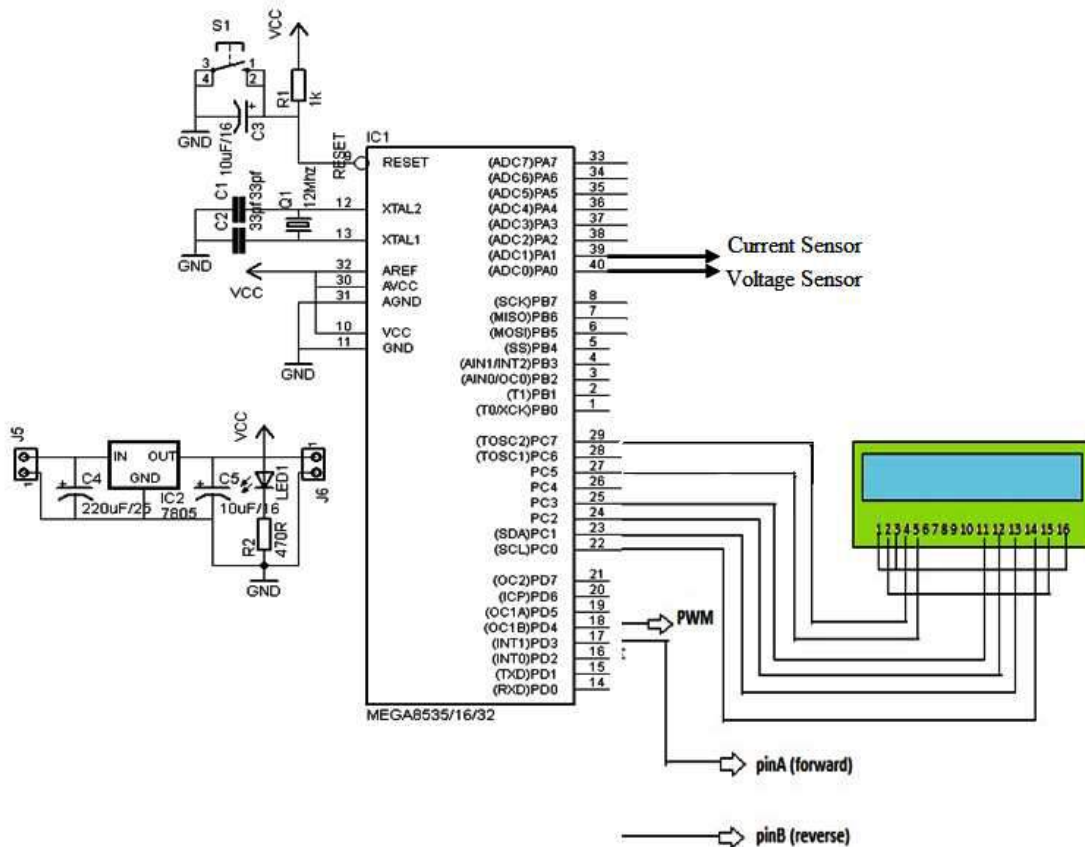

FIGURE 4. Minimum system requirement for microcontroller ATmega8535

minimum system requirement for microcontroller ATmega8535 is shown in Figure 4. This type of microcontroller has 40 ports with 32 of them are I/O ports, 32 kB memory flash and 1024 byte of EEPROM. For ADC purpose, we utilize port A.0 to port A.7. The output of voltage sensor is connected to port A.0, while the output of current sensor is connected to port A.1. The utilization of minimum system of microcontroller ATmega8535 is necessary in order to receive data from interface circuit, process data in the ADC internal unit then display the output data in LCD. The ADC data result is ADC 8 byte data with resolution of $2^8 - 1 = 255$ byte. It means that the range data resolution for ADC is between 0 and 255 (1 Kb). Port B in this microcontroller is used for display purpose in LCD. To be optimal in designing the microcontroller circuit, other supporting components, such as clock circuit (Crystal 11.0592, Capacitor 22pF and Capacitor 100nF), reset circuit (resistor 4.7 k Ω , push-button) and power supply indicators (LED and resistor 1 k Ω) are considered.

The functional configuration of port in microcontroller ATmega8535 is explained as:

- VCC is the input port for power supply circuit and GND is the port for ground
- Port A (PA.0 to PA.7) is the bidirectional I/O port with ADC input port
- Port B (PB.0 to PB.7) is the bidirectional I/O port with special function port, such as timer/counter, analog comparator and SPI
- Port C (PC.0 to PC.7) is the bidirectional I/O port with special function port, such as TWI, analog comparator and time oscillator
- Port D (PD.0 to PD.7) is the bidirectional I/O port with special function port, such as analog comparator, external interruption and serial communication
- RESET is the port to reset the microcontroller
- XTAL1 and XTAL2 is the port for input external clock
- AVCC is the input port for ADC voltage
- AREF is the input port for reference ADC voltage

To utilize the microcontroller based AVR technology, it is important to use the assembly language programming, for instance C++ language and one of the software programming for AVR microcontroller is Codevision AVR with C compiler.

2.4. Graphical user interface (GUI) based Microsoft visual basic 6.0. Microsoft visual basic 6.0 (VB6.0) is one of the powerful language programming for applications in Microsoft windows based graphical user interface (GUI). With GUI method, VB makes much easier for the programmer to have direct interaction with elements as a part of designed program for microcontroller and computer interface. GUI can be viewed as the interaction facility between users and operating systems. GUI itself can be graphs, icon, menu and pointing device. In this research, the visual basic program can be used for data acquisition application including database, chart, sending and receiving data through connection in serial port. Data is sent from microcontroller to port serial computer by IC MAX232 whose functions are to change data from the TTL voltage level of microcontroller to the RSS232 voltage level in serial port of computer. The circuit connection between the serial port and IC MAX232 can be seen in Figure 5.

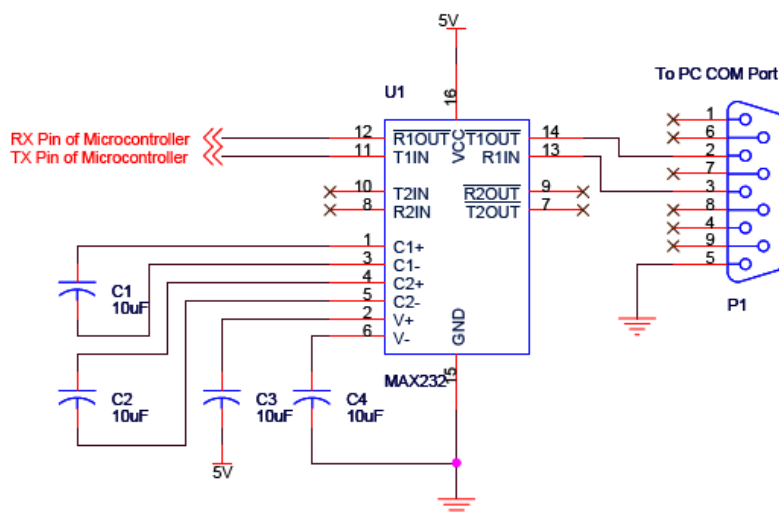

FIGURE 5. Circuit connection between the port serial of computer and IC MAX232

2.5. LCD and computer display. Display design is a very important part in this research to allow users to observe data output from processing device. The type of display devices can be liquid crystal device (LCD) and computer monitor. The LCD of 2×16 byte is very useful for visualization when processing system using microcontroller. It is very powerful to display parameters from sensor measurement, computational results, text variable and menu in the microcontroller applications. In this research, the LCD functions are to display the output power of photovoltaic system in real-time and continuous measurement. The port connection of LCD to the microcontroller ATmega8535 can be seen in Figure 6.

In this schematic diagram of LCD 2×16 byte, there are 16 ports, and each port is explained as follows:

- Port 1: Ground
- Port 2: VCC
- Port 3: Contrast adjustment
- Port 4: “RS” Instruction/Register Select
- Port 5: “R/W” Read/Write LCD registers
- Port 6: “E” Enable clock
- Port 7-14: I/O data

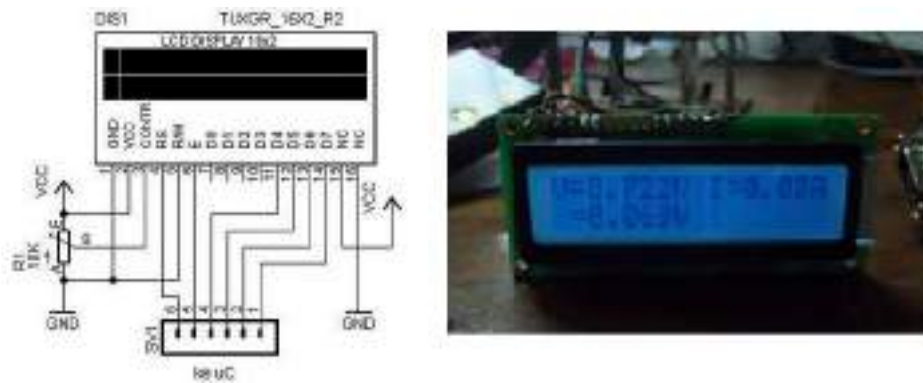

FIGURE 6. The schematic view of LCD 2×16 byte

Port 15 & 16: anode and cathode for back-lighting

Besides, the personal computer is used to run the program of visual basic 6.0, and the computer monitor can also be used as a display device. Output data from microcontroller processing is sent back to the computer through the RS232. In this case, the output power of photovoltaic system can be visualized as the graphical output as well as database output systems.

3. Testing Real-Time Simulator Design and Discussion. The proposed design of real-time and continuous monitoring of output power which is based on microcontroller utilization is connected to the photovoltaic system installation. The installation itself consists of simple photovoltaic module, charge controller, battery and DC load. The physical components of PV system are shown in Figure 7. The PV module in Figure 7(a) is a polycrystalline Silicon based technology with the maximum output 50 W. The technical specification under standard test condition (STC: 1000 W/m² and 25°C) can be seen in Table 1. Meanwhile, the charge controller in Figure 7(b) has 2 inputs connector; one connects to photovoltaic module and the other one is connected to battery. The charge controller has 3 output connected to the dc load. The technical specification of charge controller is 12 V of nominal voltage, 6 A of maximum input current, 8 A of maximum output current and fuse with 10 A. The battery and dc load in Figures 7(c) and 7(d) are liquid type battery and dc lamp with 12 V (40 Watt), respectively.

The first measurement in this research is to ensure all components, such as current sensor of ACS712, voltage sensor, microcontroller, LCD and computer working properly as an integrated system to measure the electrical parameters. One sample data measurement from 8 a.m. to 4 p.m. on 7th June, 2012 is shown in Table 2.

In this measurement, a constant voltage for DC load is set to 12 V; therefore, both actual and sensor are showing similar measurement results. The voltage set-up is little lower than one on the input of irradiance condition that may affect the photocurrent output of photovoltaic module. The ideal condition for the current at maximum power point is 2.84 A, however, in this testing results, the current range between 2.70 A and



FIGURE 7. The physical components of PV system

TABLE 1. PV module specification under standard test condition

Power at maximum power point (P_{mp})	50 W _p
Open circuit voltage (V_{oc})	21.6 V
Short circuit current (I_{sc})	3.01 A
Voltage at maximum power point (V_{mp})	17.6 V
Current at maximum power point (I_{mp})	2.84 A
Working temperature	-45°C to +85°C
Tolerance	±5%

TABLE 2. Actual and sensor LCD measurement for current, voltage and output power

Time measurement	Voltage (V)		Current (A)		Power (W)	
	actual	sensor	actual	sensor	actual	LCD
08.00 a.m.	12	12	2.75	2.70	33.00	32.40
08.30 a.m.	12	12	2.77	2.78	33.24	33.36
09.00 a.m.	12	12	2.77	2.77	33.24	33.24
09.30 a.m.	12	12	2.78	2.77	33.36	33.24
10.00 a.m.	12	12	2.80	2.81	33.60	33.72
10.30 a.m.	12	12	2.81	2.80	33.72	33.60
11.00 a.m.	12	12	2.81	2.80	33.72	33.60
11.30 a.m.	12	12	2.82	2.81	33.84	33.72
12.00 (noon)	12	12	2.84	2.84	34.08	34.08
00.30 p.m.	12	12	2.83	2.82	33.96	33.84
01.00 p.m.	12	12	2.83	2.82	33.96	33.84
01.30 p.m.	12	12	2.82	2.81	33.84	33.72
02.00 p.m.	12	12	2.82	2.81	33.84	33.72
02.30 p.m.	12	12	2.81	2.79	33.72	33.48
03.00 p.m.	12	12	2.81	2.79	33.72	33.48
03.30 p.m.	12	12	2.80	2.78	33.60	33.36
04.00 p.m.	12	12	2.77	2.75	33.24	33.00

2.84 A can be achieved. Because the operating point is not exactly in the maximum power point output, the efficiency of output power is only 67% (both actual and LCD measurements). If the DC load is exactly matched with the setting up of maximum output power, for instance the operating voltage is 15 V, then the efficiency can be increased to 84%. This is merely the mismatching problem between the photovoltaic outputs to the ideal load for the PV system.

In terms of sensor accuracy to the actual parameters, voltage sensor can be guaranteed at high accuracy; but not the current sensor. The current sensor has still small deviation about 0.48% between the actual point measurement and output sensor measurement. It is due to the instability performance of internal ADC of the microcontroller ATmega8535. As results, there will be a defective output power measurement in LCD display. Nevertheless, in this case, the measurement difference is very small which is about only 0.67%.

The proposed design for real-time and continuous output power measurement of photovoltaic system is suitable for high capacity installation. For the number of module increases, the sensor circuit must be modified according to configuration photovoltaic systems. In the market, the current sensor is easily found with different ratings, for instance 5 A, 10 A, 20 A and 30 A. For current rating 30 A, it will be suitable for PV panel configuration with 10 modules in parallel (short circuit current is 3 A per module). The advantage of our proposed system is not necessary to replace the voltage sensor even after the PV system configuration changes. Only the value of resistance is updated based on

the number of PV panel in parallel. The value resistor in the market is available between 1Ω and $910 \text{ k}\Omega$. With the open-circuit voltage of 21.6 V and the value of resistance of $910 \text{ k}\Omega$, the number of PV module in series can be 210 with current sensor of 5 A .

4. Conclusion. It is very interesting to visualize the output power measurement of photovoltaic system in real-time and continuously. It is not only because the environmental factors vary that makes the output power changes but also the different technologies in solar cells have different responses and characteristics to input parameters. The real-time output with continuous measurement is possible due to the rapid development of sensors and electronic devices. The fundamental design of our proposed real-time measurement system is based on the utilization of Hall Effect of ACS712 current sensor and voltage sensor. The output parameters of these two sensors are processed in microcontroller ATmega8535 in order to obtain output power in real-time and continuously in liquid crystal display (LCD) or in computer monitor. The performance of microcontroller ATmega8535 and sensors circuits are regulated using C++ combined with Visual Basic 6.0 language programming for display interface and database systems. The performance of our proposed design can be guaranteed at high accuracy determined by the deviation to the actual measurement. In addition, the proposed design for real-time and continuous output power measurement of photovoltaic system is suitable for high capacity installation.

REFERENCES

- [1] Syafaruddin, E. Karatepe and T. Hiyama, Artificial neural network – Polar coordinated fuzzy controller based maximum power point tracking control under partially shaded conditions, *IET Renewable Power Generation*, vol.3, no.2, pp.239-253, 2009.
- [2] Syafaruddin, E. Karatepe and T. Hiyama, Polar coordinated fuzzy controller based real-time maximum power point control of photovoltaic system, *Renewable Energy*, vol.34, no.12, pp.2597-2606, 2009.
- [3] Syafaruddin, E. Karatepe and T. Hiyama, Comparison of ANN models for estimating optimal points of crystalline silicon photovoltaic modules, *IEEE Transactions on Power and Energy*, vol.130, no.7, pp.661-669, 2010.
- [4] P. Singh and N. M. Ravindra, Temperature dependence of solar cell performance – An analysis, *Solar Energy Materials and Solar Cells*, vol.101, pp.36-45, 2012.
- [5] A. Garrigós, J. M. Blanes, J. A. Carrasco and J. B. Ejea, Real time estimation of photovoltaic modules characteristics and its application to maximum power point operation, *Renewable Energy*, vol.32, no.6, pp.1059-1076, 2007.
- [6] F. Spertino and F. Corona, Monitoring and checking of performance in photovoltaic plants: A tool for design, installation and maintenance of grid-connected systems, *Renewable Energy*, vol.60, pp.722-732, 2013.
- [7] T. Khatib, K. Sopian and H. A. Kazem, Actual performance and characteristic of a grid connected photovoltaic power system in the tropics: A short term evaluation, *Energy Conversion and Management*, vol.71, pp.115-119, 2013.
- [8] W. Wang, N. Li and S. Li, A real-time modeling of photovoltaic array, *Chinese Journal of Chemical Engineering*, vol.20, no.6, pp.1154-1160, 2012.
- [9] J. I. Rosell and M. Ibáñez, Modelling power output in photovoltaic modules for outdoor operating conditions, *Energy Conversion and Management*, vol.47, no.15-16, pp.2424-2430, 2006.
- [10] Y. Su, L.-C. Chan, L. Shu and K.-L. Tsui, Real-time prediction models for output power and efficiency of grid-connected solar photovoltaic systems, *Applied Energy*, vol.93, pp.319-326, 2012.
- [11] Y. Wang, G. Ouyang and X. Zhang, Data processing of photovoltaic system on DSP 2812, *Procedia Engineering*, vol.23, pp.109-114, 2011.
- [12] E. Koutroulis, K. Kalaitzakis and V. Tzitzilouis, Development of an FPGA-based system for real-time simulation of photovoltaic modules, *Microelectronics Journal*, vol.40, no.7, pp.1094-1102, 2009.
- [13] A. M. Pernía, J. Arias, M. J. Prieto and J. Á. Martínez, A modular strategy for isolated photovoltaic systems based on microcontroller, *Renewable Energy*, vol.34, no.7, pp.1825-1832, 2009.
- [14] L. Khemissi, B. Khiari, R. Andoulsi and A. Cherif, Low cost and high efficiency of single phase photovoltaic system based on microcontroller, *Solar Energy*, vol.86, no.5, pp.1129-1141, 2012.
- [15] Y. Yu and C. Yao, Implementation of a MPPT controller based on AVR Mega16 for photovoltaic systems, *Energy Procedia*, vol.17, pp.241-248, 2012.